

# Series 200 LC Pumps

## Isocratic, Binary, Quaternary and Micro Flow – Built to Withstand the Test of Time



Top performance characteristics are what you have come to expect from PerkinElmer® LC pumps. We've taken this exceptional patented design and put it all into a common, upgradable pump platform. The PerkinElmer Series 200 Pumps – a fifth-generation pump with superior flow-rate precision, compositional accuracy and exceptional retention-time repeatability for all of your separations – isocratic or gradient. While the new Series 200 Micro Pumps provide precise, high-pressure gradients and pulseless flow for microbore, narrowbore, LC/MS and analytical requirements.

The PerkinElmer Series 200 Pump provides stand-alone capability or full external control through the TotalChrom® Chromatography Workstation. Start out with the isocratic version now and upgrade

to full binary or quaternary gradient capability – all within the same pump – we'll ship you a cost-effective upgrade kit for easy installation right in your lab.

### Proven, rugged and reliable design

- Upgradable isocratic, binary, and quaternary versions as well as biocompatible options for maximum flexibility.
- Micro Pump format for ultra-low flow-rate applications.
- Small, compact design [12 inches (30.5 cm) wide] saves valuable bench space.
- Large back-lit LCD screen allows clear viewing of pump method and status parameters at all times.
- Solvent-resistant front panel with rounded ergonomic design for easier interaction with keypad.
- TotalChrom ready – just connect to the link interface and go! No upgrades or additional cables required!
- Tactile keyboard with unique “key click” so that you know your entry was made.
- Snap-in contact closure connections and finger-tight plumbing fittings make it simple to connect or disconnect your system.
- Visual-access front-door panel allows quick plumbing inspection and easy access to prime purge valve.
- Pump module can be accessed or completely removed to lab bench for maintenance without having to “unstack” modules via unique slide-out design.

## Comprehensive method and editing power

- Directory of up to 20 methods, 20 steps each, with built-in method linking increases sample throughput.
- Edit the active method in real-time with easy-access function keys.
- Automatic shutdown of the pump method at your final gradient conditions.

- Graphic display of solvent profile on-screen shows real-time modifications to gradient method.
- Hold gradients or advance to the next step with a simple keystroke.

## Complete diagnostics and method documentation simplifies GLP compliance

- Full method documentation including modifications with

method name, number, date and time stamp.

- Maintenance Log coded by the serial number of the pump, including pump and seal cycles.
- Extensive service diagnostics.
- Instrument Log records history of operation for quick diagnosis and servicing to get you up and running in no time.

## Our customers tell us that PerkinElmer's pump design offers the best flow rate precision. Here's why...

- |   |   |
|---|---|
| <b>A Automated Solvent Compensation</b>     | Maintains a continuous and constant flow with each pump stroke using patented real-time blending compensation, which accounts for and meters different volumes according to the solvent shrinkage that occurs with mixing. This same principle corrects for solvent compressibility changes.  |
| <b>B Minimal Pulsations</b>                 | Minimizes pressure pulsations due to high-speed retraction of delivery piston with every stroke (65 msec.)  |
| <b>C Low Mixing Volume*</b>                 | Provides high-efficiency solvent mixing resulting from extremely high turbulence inside the pump when the pump transfers the next increment of solvent from the low-pressure piston to the high-pressure piston at a high flow rate (100 mL/min).   |
| <b>D No Air Bubbles</b>                     | Eliminates cavitation or bubbles as a result of the unique, patented design that provides positive transfer of the next increment of solvent under pressure rather than vacuum refilling, as is typically done with other pumps. In the schematic, the delivery chamber is about to be positively refilled from the metering chamber. |
| <b>E Superior Low Flow-Rate Performance</b> | Operates efficiently even at lower flow rates because of the double-check valve design that prevents solvent backflow on each delivery stroke.  |

## Time-proven design keeps your lab going

PerkinElmer pumps are built to keep running. We ensure that the pump going into your laboratory is fully-tested and calibrated to ensure reliable, trouble-free operation all day, every day. Our quality assurance laboratory reports that the typical Mean Time Between Failure (MTBF) is a minimum of 4400 hours – that's two years of continuous operation with no failures of any kind (8 hours a day, 5 days a week). PerkinElmer pumps are still the lowest maintenance pumps on the market with the most rugged design.

## Schematic of the Series 200 Pump

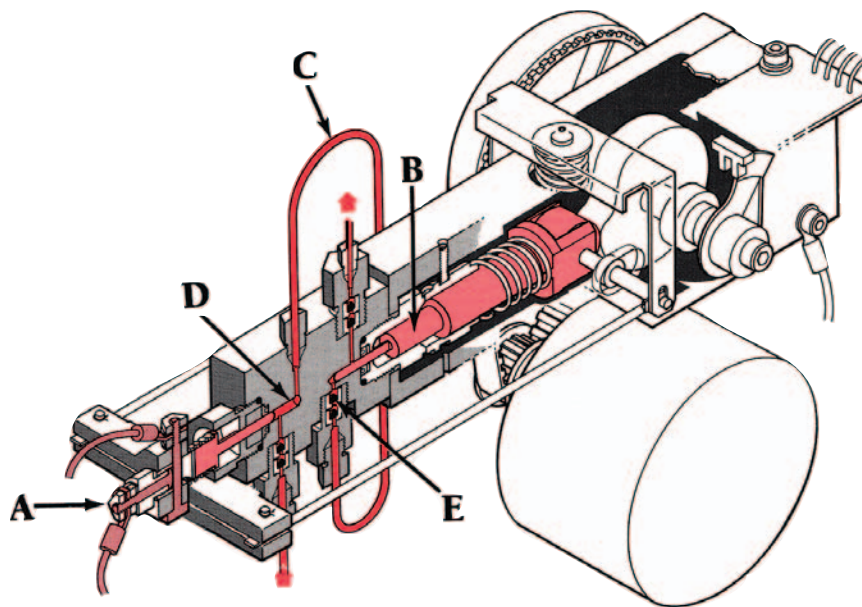

\* Enhanced performance available via Series 200 Micro Pumps

**Time-proven design provides outstanding flow rate reproducibility, superior compositional accuracy and unsurpassed gradient performance**

- **Unsurpassed Compositional Accuracy.** The proportioning of the Series 200 Pump has been designed so that the minor component is always “sandwiched” between the major components. In this way, compositional accuracy is preserved even when one mobile phase component is mixed at a very low percentage.
- **No External Mixing Volume Is Required.\*** All mixing is done inside the pump. This is accomplished after the metering stroke when proportioned solvent is transferred to the high pressure side at 100 mL/min. The resulting turbulence causes thorough mixing and eliminates the need for an external dynamic mixer.

**Series 200 Pump detail**

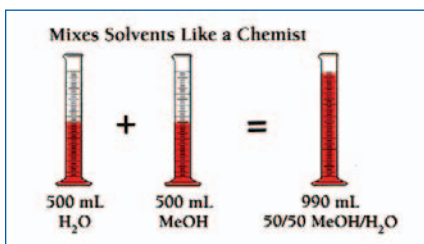
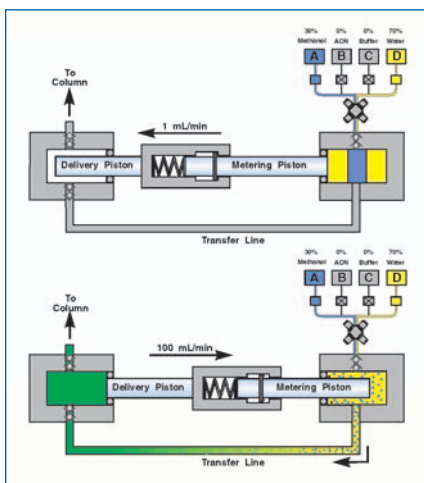

\* For standard Isocratic, Binary and Quaternary pumps.

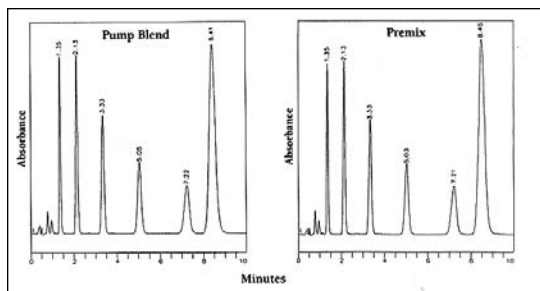

Figure 1. Identical results from premixed (mixed by hand) and pump-blended mobile phases demonstrate the patented real-time blending compensation, illustrating that the pump mixes as accurately as you do. This allows direct method transfer from the method development laboratory to the QC laboratory.

Note that this is a four-solvent blend.

**Conditions:**

Sample: Substituted benzene test mix  
 Mobile Phase: 44% methanol; 10% Acetonitrile; 6% THF; 40% H<sub>2</sub>O  
 Column: 3 μm PE 3x3CR C18  
 Flow Rate: 1 mL/min  
 Detection: UV at 250 nm

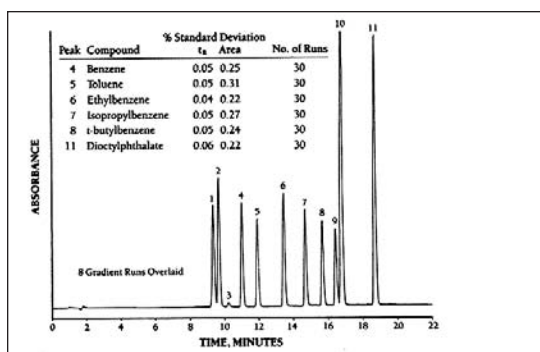

Figure 2. Overlay of replicate gradient assays of substituted benzenes using the Series 200 Pump demonstrates the unprecedented gradient mixing and reproducibility for the most accurate analysis (<0.06% RSD of retention time).

**Conditions:**

Mobile Phase: 10% to 100% methanol/water in 10 minutes, linear gradient  
 Column: 3 μm PE 3x3CR C18  
 Flow Rate: 1.5 mL/min  
 Detection: UV at 250 nm

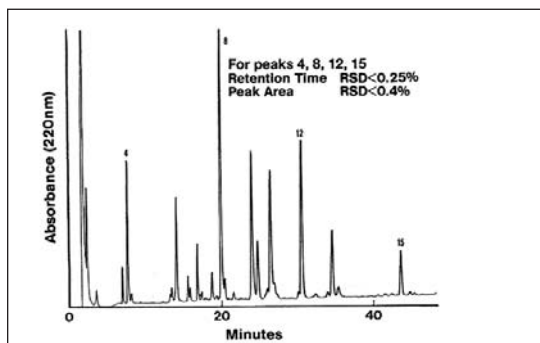

Figure 3. Reproducible gradient performance, crucial in obtaining accurate results, is illustrated in this overlay of six tryptic maps of lysozyme. This peptide map demonstrates a true test of pump performance (1). As noted in the literature, peptide mapping using shallow gradients is one of the most demanding separations in HPLC (2). Clearly, the Series 200 Pump operates accurately and precisely even under the most strenuous gradient conditions.

**Conditions:**

Column: 5 μm Vydac C18 (150 x 4.6 mm)  
 Mobile Phase: A = 0.1% TFA in ACN; B = 0.1% TFA  
**Gradient:**  
 Conditions: 0-15% A in 15 minutes, 15-30% A in 40 minutes  
 Flow Rate: 1 mL/min at 40 °C

## Series 200 Pump Specifications

	Series 200 Micro Pumps	Series 200 Analytical Pumps
Flow-Rate Range	1 µL/min - 3 mL/min	0.01 to 10.0 mL/min
Flow-Rate Increments	1 µL/min from 0 to 0.999 mL/min; 0.01 to 3 mL/min	0.01 from 0 to 0.99 mL/min; 0.1 from 1.0 to 10 mL/min
Flow Precision	0.3% RSD (typical 0.1%) at 300 µL/min water @ 1000 psi	0.3% RSD (typical 0.1%) at 1 mL/min water @ 1000 psi
Flow Accuracy	±1% of setting at 300 µL/min and 1000 psi with water	±1% of setting at 1 mL/min and 1000 psi with water
Retention-Time Reproducibility	<0.3% RSD (typically <0.1%)	<0.3% RSD (typically <0.1%)
Pressure Range	0 to 6200 psi for the entire flow-rate range	0 to 6200 psi for the entire flow-rate range
Compositional Range	0 to 100%, settable to 1%	0 to 100%, solvent A to D, settable to 0.1%
Compositional Accuracy	Typically 0.5% from 10 to 90% up to 2 mL/min	Typically 0.5% from 3 to 97% up to 5 mL/min
Compositional Precision	Typically <0.2% variation	Typically <0.2% variation
Gradient Forms	Linear, convex and concave with high-pressure blender	Linear, exponential 1 to 9.9 (positive and negative) or step (89 profile selections)
Linearity	Within 1% from 10 to 90%	
Program Steps	Step 0 (Equil) plus up to 20 solvent program steps; Battery-backed storage of up to 20 methods plus 1 edit method and 1 default method	
Step Time	0 to 999 minutes	
Step-Time Increments	0.1 min from 0 to 9.9 min; 1.0 min from 10 to 999 min	
Timed Events	Two built-in independent momentary (2-second) contact closures	
Events / Method	Max of 9	
Event Increments	0.1 min from 0 to 9.9 min; 1.0 min from 10 to 999 min	
Dimensions	(H x W x D) 14 cm x 30.5 cm x 43 cm (Binary Micro Pump 30 cm height)	
Weight	27.3 kg (60 lbs)	

## Ordering Information

Part Number	Description
N2910100	Series 200 LC Pump Isocratic Version (50/60 Hz)
N2910101	Series 200 LC Pump Binary Version (50/60 Hz)
N2910102	Series 200 LC Pump Quaternary Version (50/60 Hz)
N2910202	Series 200 BIO LC Pump Quaternary Version (50/60 Hz)
N2910500	Series 200 Micro Pump Isocratic Version (50/60 Hz)
N2910503	Series 200 Micro Pump Binary Package (50/60 Hz) (includes a Series 200 Dynamic Mixer)
N2910342	Series 200 Upgrade Kit – Isocratic to Binary
N2910343	Series 200 Upgrade Kit – Isocratic to Quaternary
N2910344	Series 200 Upgrade Kit – Binary to Quaternary

### References:

1. M.W. Dong, J.R. Gant, "A High-Sensitivity LC System for Peptide Mapping," American Biotechnology Laboratory, 7(6), 1989.
2. E.R. Hoff, "A Biotechnology Approach to Assessing HPLC Gradient Performance," LCI GC, 7(4), 1989.

PerkinElmer Life and  
Analytical Sciences  
710 Bridgeport Avenue  
Shelton, CT 06484-4794 USA  
Phone: (800) 762-4000 or  
(+1) 203-925-4602  
[www.perkinelmer.com](http://www.perkinelmer.com)



For a complete listing of our global offices, visit [www.perkinelmer.com/lasoffices](http://www.perkinelmer.com/lasoffices)

©2007 PerkinElmer, Inc. All rights reserved. The PerkinElmer logo and design are registered trademarks of PerkinElmer, Inc. PerkinElmer and TotalChrom are registered trademarks of PerkinElmer, Inc. or its subsidiaries, in the United States and other countries. All other trademarks not owned by PerkinElmer, Inc. or its subsidiaries that are depicted herein are the property of their respective owners. PerkinElmer reserves the right to change this document at any time without notice and disclaims liability for editorial, pictorial or typographical errors.